



**PRESSURE  
REDUCING VALVE  
[FDI - PRV - 704]**

**BACK PRESSURE  
REDUCING VALVE  
[FDI - BPRV - 705]**



## INDEX

- Introduction
- Features
- Product General Specification
- Standard and Certifications
- Order Guide & Recommended Spares

# INTRODUCTION

## (PRESSURE REDUCING VALVE)

Pressure Reducing Valve is used to lower pipeline pressure to a pre-set value in water system and building service application. Automatically, quietly and smoothly control downstream pressure. The valve maintains a preset downstream pressure, regardless of upstream pressure or flow fluctuation. The main valve is controlled by a pilot valve, which makes the main valve modulating to maintain the downstream pressure. The pressure reducing valve shall reduce higher upstream pressure to lower pre-set downstream pressure regardless of fluctuating demand or varying upstream pressure.



## MAIN VALVE

The main valve shall be a center guided, diaphragm actuated globe valve of either oblique(Y) or angle pattern design. The body shall have a replaceable, raised, stainless steel seat ring. The valve shall have an unobstructed flow path, with no stem guides, bearings, or supporting ribs. The body and cover shall be ductile iron. All external bolts, nuts, and studs shall be Duplex coated. All valve components shall be accessible and serviceable without removing the valve from the pipeline.

## ACTUATOR

The actuator assembly shall be double chambered with an inherent separating partition between the lower surface of the diaphragm and the main valve. The entire actuator assembly (seal disk to top cover) shall be removable from the valve as an integral unit. The stainless-steel valve shaft shall be centre guided by a bearing in the separating partition. The replaceable radial seal disc shall include a resilient seal and shall be capable of accepting a V-Port Throttling Plug by bolting.

## CONTROL SYSTEM

The control system shall consist of a 2-way adjustable, direct acting, pressure reducing pilot valve, a needle valve, isolating cock valves, and a filter.

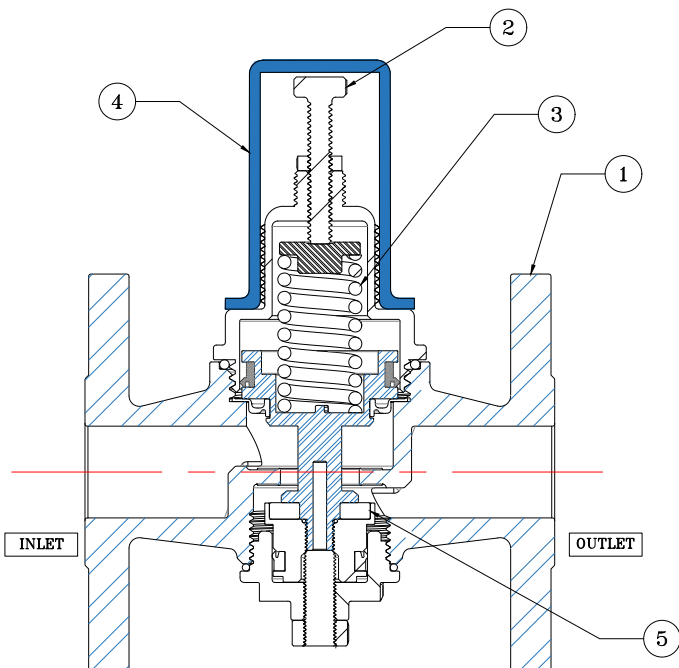

1. BODY
2. ADJUSTABLE BOLT
3. SPRING
4. CAP
5. GASKET/PACKING

# INTRODUCTION

## (PRESSURE REDUCING VALVE)

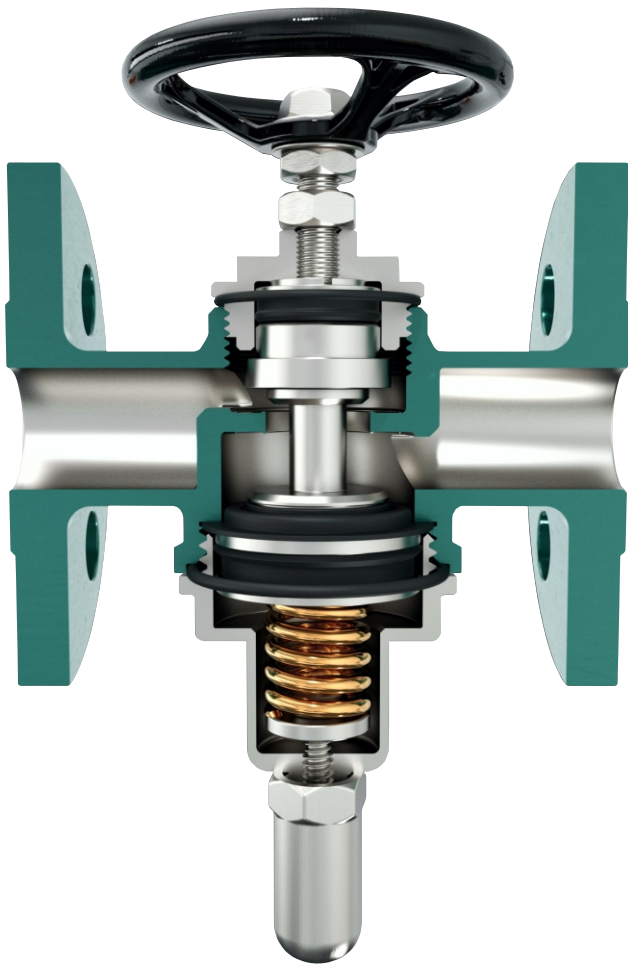

## CONTROL SYSTEM

All Fittings shall be forged brass or stainless. The assembled valve shall be hydraulically tested and factory adjusted to customer requirements.

## QUALITY ASSURANCE

The Valve manufacturer shall be certified according to the ISO 9001 Quality Assurance Standard. The main valve shall be certified as a complete drinking water valve according to NSF, WRAS, and other recognized standards.

The pressure reducing valve may be used for water hammer protection under properly defined conditions. The water hammer events are so fast that the relief of pressure by this means requires very special rapid response valves designed for the particular system.

A Pressure Reducing Valve holds a consistent set point downstream of the valve.

- Beginning with the control valve in a closed position and the adjusting screw not yet calibrated to a desired set point, the upstream pressure begins to flow—in this example, up to a pressure of 400 PSI.
- No supply pressure is available yet to move the valve open.
- Upstream pressure flows into the Drip Pot, which knocks out liquid from the supply gas which could be detrimental to other instruments.
- As the pressure approaches the set point, there is enough force pushing up the pilot diaphragm assembly to move it up and reposition the pilot plug.
- Now, supply pressure is blocked from going into the control valve actuator, and instead the diaphragm pressure is rerouted out through the pilot and vented.

## WORKING PROCEDURE

The PRV body's disc assembly will rise and the PRV valve opened from inlet pressure or haven't adjusting the pilot valve, the needle valve under opened condition and no heavy load on adjusting bolt, the fluid will let through pilot tube to pilot valve from upper part of the diaphragm in the PRV body. (...continue...)

# INTRODUCTION

---

## (PRESSURE REDUCING VALVE)

The lower part of the diaphragm in the pilot valve pressure increase, the disc assembly of the pilot valve will rise, and the pilot valve will closed.

The pilot valve closed, the upper part of the diaphragm in the PRV body pressure will increase, the PRV disc assembly will drop down, and the PRV closed.

To setting outlet pressure of the PRV, removed the cap which on top of the pilot valve, clockwise turn the adjustment bolt, the outlet side pressure will increase, turn anti clockwise will reduce the pressure.

## INSTALLATION

---

- Thoroughly clean or flush out piping system to remove any foreign material etc. otherwise it could cause damage to sealing surfaces during valve operations.
- Piping should be properly aligned and supported to reduce undue mechanical loading on the end connections.
- Verify that the space available is adequate to allow the PRV to be installed and to be operated, comfortably.
- Insufficient clearance for removal of the Filter cap or Bonnet may cause difficulty in opening valve for maintenance in future. Also sufficient clearance should be allowed for threaded valves to rotate on it's axis during installation.
- Install pressure reducing valve
  - Check that arrow is in flow direction, (indicated by arrow on pressure reducing valve body)
  - Install without tension of bending stresses.
- End Connection :- Check condition of threads on mating pipe. Apply compound for fixing valve to the male end of joint usually the pipe only
- Though FDIPL PRV'S can be installed in any position. It is easier to collect & remove dirt when put in horizontal line.
- PRV is now ready for use.

### **Post - installation Procedure**

After installation, the line should be cleaned by flushing to remove any foreign material. With the line pressurized, check the valve end connections for any leaks. The packing may have to be tightened to stop packing leakage/ sweating at the system pressure.



# INTRODUCTION

## (BACK PRESSURE REDUCING VALVE)

A back pressure reducing valve is a valve that maintains a defined pressure upstream of its own inlet. When fluid pressure at the inlet of the back pressure reducing valve exceeds the set point, the reducing valve opens to relieve the excess pressure. The back pressure reducing valve continually adjusts its position to keep the inlet pressure at the desired set point.

In the normally closed position, upstream pressure is sensed underneath the diaphragm. As upstream pressure increases above the set point, the pressure of the service overcomes the spring force and begins opening the valve. This bleeds off the pressure on the upstream pressure side and maintains the constant upstream pressure.

Benefits of Using Back Pressure Reducing Valve Some of include:



- Straight-through flow where turbulence is reduced and superior trim life is achieved.
- Sliding gate design provides exceptional low flow control since the flow works with the seat and not against it.
- Short stroke with fast response. The stroke length is typically that of a Globe Valve, Reducing the amount of droop (deviation from set point) in the reducing valve.
- A variety of seat coatings and seat materials to meet almost any application. The Fidicon seat is standard and delivers outstanding performance.
- The sliding gate design provides an area of closure, not just a line of closure. This area of closure reduces the effects of wire draw which is the most common cause of seat leakage.
- Less maintenance and downtime, and more opportunity to increase yields and profits.
- Easy maintenance. Your flow requirements change, and interchangeable Cv's are available.
- The movement of the sliding gate seats generates a self-cleaning action.

## RECOMMENDED DISPOSAL

- Give it back to us & we will take care of recycling & possible disposal.
- User can dis-assemble the product in multiple stage
- The above may be handed over (state pollution board), authorized re-cycler item-wise.

# INTRODUCTION

## (BACK PRESSURE REDUCING VALVE)



## APPLICATION OF VALVE

Fidicon Back pressure reducing valves are ideal for steam, liquid, and gas media applications.

- For use in the food & beverage industry
- For High-Pressure applications
- For fuel and oil burner control
- For fuel and oil atomization
- For natural gas applications
- For steam sterilization

Our team works with our customers to help achieve tangible results including lower operating costs, optimized performance, prolonged equipment life and higher productivity.

## MAINTENANCE PROCEDURE

### REPLACE DIAPHRAGM / SEAT

- 1 Release adjust spring compression by turning the adjusting bolt counter clockwise until it turns freely without resistance from the adjust spring.
- 2 Remove bolt/nut and lift off the upper diaphragm case, spring, upper spring seat.
- 3 Unscrew the diaphragm lock nut from the stem in order to separate the parts of the diaphragm. lift off the diaphragm plate, diaphragm holder, diaphragm.
- 4 Remove the diaphragm and examine for damage. Replace if damage is verified.
- 5 Unscrew the Lower Cap Screw from the lower diaphragm case in order to separate the parts of the bonnet. lift off the lower diaphragm case.
- 6 Remove stud/nut and lift off the bonnet.
- 7 After separating the valve plug, cage and seat, inspect the seating surface of the valve plug, make sure that the elastomer or polished metal surface of the valve plug is not damaged. Replace if damage is verified.
- 8 Inspect the seating edge of the seat. If damage is verified. remove the seat and replace it with a new part.
- 9 If no further maintenance is required, reassemble the valve in the reverse of the above steps.



## ENQUIRY SPECIFICATIONS:

- [1] Service Media Details.
- [2] Tank Volume, Type, MOC of Tank, Dimensions for Fire Exposure.
- [3] Pump Flow ( In-Charge, Discharge Flow Rate )
- [4] Product Design Condition ( Normal Vent / Fire )
- [5] N2 Blanketing System Available ( If Yes, Flowrate / No )
- [6] System Operating and Design Pressure.
- [7] System Operating and Design Temperature.
- [8] Set Pressure Requirements
- [9] Material Specifications ( Body, Internal )

## RECOMMENDED SPARES

- [1] Stem
- [2] Spring
- [3] Adjusting Bolt
- [4] Spring Washer
- [5] Diaphragm

## OTHER RANGE OF PRODUCTS

- [1] Flame Arrester
- [2] Breather Valve
- [3] Level Indicators
- [4] Rotameters
- [5] Emergency Relief Valve
- [6] Gauge Hatch
- [7] Strainers
- [8] Pressure Reducing Valve
- [9] Safety Relief Valve
- [10] Flowmeters
- [11] Level Switches
- [12] Pressure Reducing Station
- [13] Level Gauge, etc.

### Any Query?

Contact us to Discuss,

Phone No: +91-2646-222238/223412

Mobile No: +91-9824418777

[sales@fidicondevices.com](mailto:sales@fidicondevices.com)

[info@fidicondevices.com](mailto:info@fidicondevices.com)

Address: Plot No. 1706/12, GIDC Ankleshwar,  
Dist.: Bharuch, Gujarat, India 393002.

