

# FLAME ARRESTER IN-LINE BI DIRECTIONAL

MODEL : [FDI-FA-707]

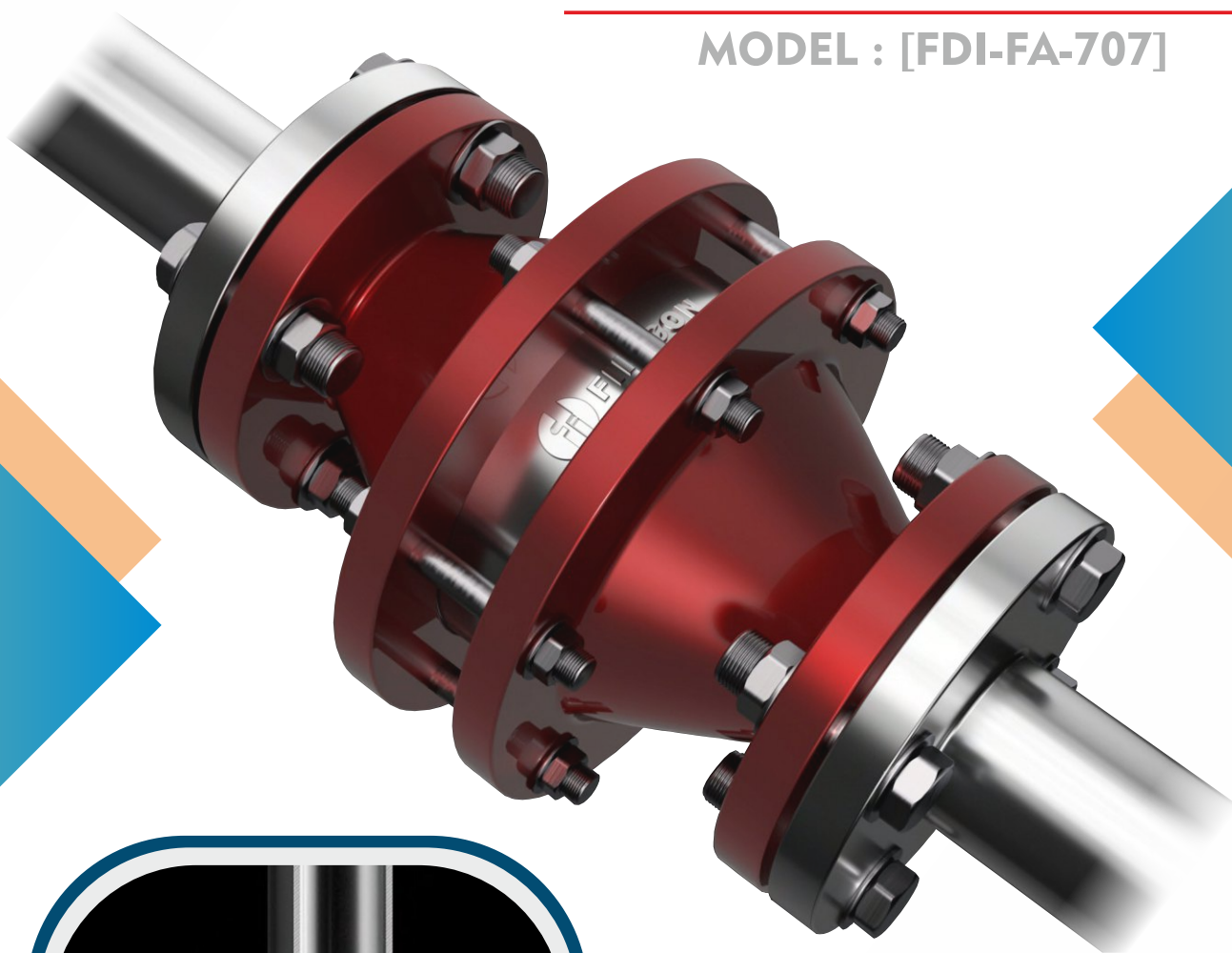

## INDEX

1. Introduction to Flame Arrester
2. Specification
3. Selection Criteria
4. Product Functionality
5. Application, Performance, Benefits & Testing Overview
6. Standard & Certifications
7. Order Guide & Recommended Spares.

 **FIDICON**  
DEVICES INDIA PRIVATE LIMITED

*Dedicated to People & Environment Protection*

# INTRODUCTION : FLAME ARRESTER

In Simple terms ,Flame Arrester are Static Passive Safety Device that allows transmission of gas and vapors mixtures, and it prevents the Fire Transmission.

Failure to stop a Flame propagation - Explosion by primary safety devices like Isolation Valve, Hydraulic Seals, Oxygen Analyzer, Multigas Analyzer etc., can result in extensive damage to personnel, equipment, environment and potential loss of production. that's why Flame Arresters are used as Passive-Backup Device to Improve Safety.

So, Working principle of this is based on Combustion Triangle, for Combustion Three Elements needed as,

- 1) Fuel - which here in our case is Gas and Vapors mixtures
- 2) Oxygen - which is obtained through air mixture
- 3) Heat - (or Temperature) which can be elevated through uncertain various parameters.

There are several classification of this device, but mainly it goes by,

- 1) In Line Type Flame Arrester  
- generally connection is in between the pipeline nearby to the potential Ignition Source.
- 2) End of Line Type Flame Arrester  
- which is free to atmosphere - free vent type.

Further Sub-Categories are based on type of Explosions can occur, like Deflagration & Detonation which are defined by Speed of Explosion. Deflagration is considered when Explosion Speed is Below Supersonic and Detonation is considered for Supersonic speed and Above. Speed of Explosion can differ from L/D Ratio in Pipeline System. Mostly ,  $L/D < 50$  is Deflagration, and  $L/D > 50$  falls under Detonation Category , can be calculated with Reference to Potential Ignition Source in your Pipeline System.

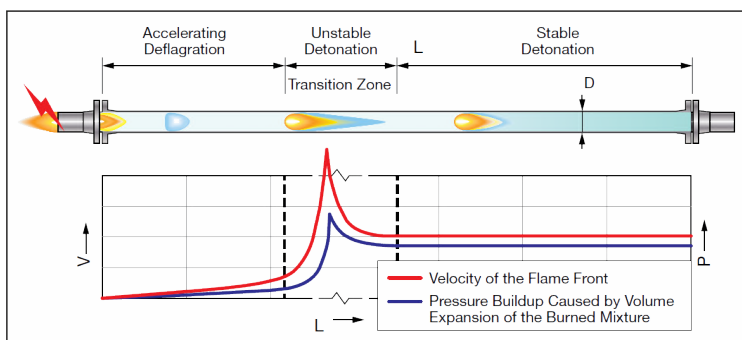

So, as Flame Arrester working principal is by Reducing Temperature-Heat, Heat should be absorbed efficiently, but majority of the time Explosions are for very short amount of time (very quick speeds - supersonic - Mach  $\geq 1$ ), so in this very quick moments heat isn't absorbed quickly with respect to it's speed. that's where flame quenching is presented.

Flame Quenching means to distribute - break - separate the flames into small flamelets (voxels) by passing the Flame through very narrow gaps up to 0.2 mm , where it will extinguish due to heat loss and insufficient air and only gas-smoke may pass which is below the flashpoint of that particular gas / vapors.

Definitely Narrower the gap , greater the extinguishing effectiveness but, gap have been optimized through various tests relative to gas-vapor flashback capacity , flashback - Explosion Redirects to it's source path. this optimized narrow gaps are also known as M.E.S.G. (Maximum Experimental Safe Gap), Derived for each Gas and Gas Groups which is helpful in selection process of Flame Arresters for your Application.

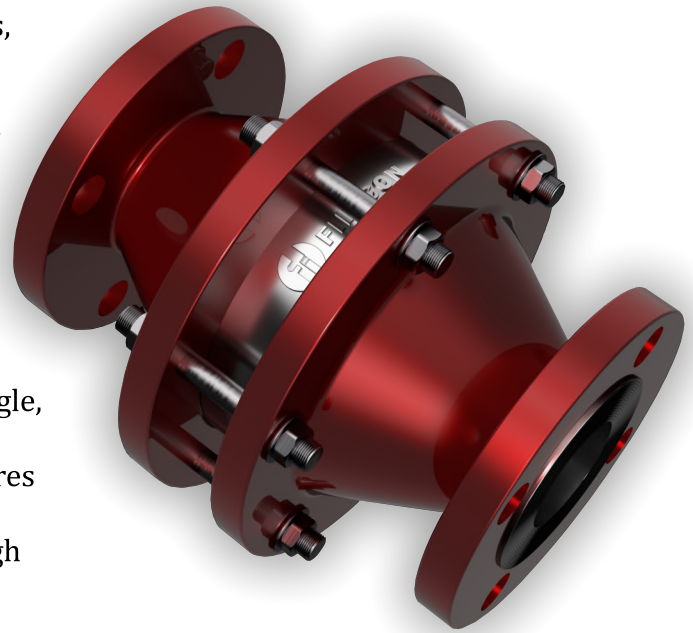

# Specifications - MESG - Maximum Experimental Safe Gap

Each Gas and Gas Groups have different Flame Propagation capacities and further categorized in explosion groups corresponding to their hazard level. The standard for characteristic values measured in Laboratory for flame propagation ability of the Product.

MESG or Standard gap width is the largest gap width between the two parts of the interior chamber of a test setup which, when internal gas mixture is ignited under specific conditions, prevents ignition of the external gas mixture through 25mm Long gap for all concentrations of tested gas vapor in air.

MESG is Property of Respective gas mixture [EN-1127-1], the test setup and methods are specified in [EN 60079-20-1]. The Most explosive composition is close to the stoichiometric mixture of gas-vapor-air.

## Gas Groups

### Group A

Acetylene

### Group B (II C)

Butadiene

Ethylene Oxide

Hydrogen Processed  
Gases Containing  
more than 30%  
Hydrogen By Volume

Propylene Oxide  
Propyl Nitrate

### Group C (II B)

Acetaldehyde  
Cyclopropane  
Diethyl Ether  
Dimethyl Hydrazine  
Ethylene  
Hydrogen Sulphide  
Methanol ( Methyl Alcohol )  
Methyl Mercaptan  
Unsymmetrical Dimethyl  
Hydrazine  
UDMN

### Group D (II A)

Acetone  
Acrylonitrile  
Ammonia  
Benzene  
Butylene  
Butyl Alcohol  
Secondary Butyl Alcohol  
Cyclohexane  
N-Butyle Acetate  
Isobutyl Acetate  
Ethane  
Ethanol  
Ethyl Acetate  
Ethane Dichloride  
Gasoline  
Heptanes  
Hexanes  
Isoprene  
Methane-Natural Gas  
Methyl Acrylate  
Methylamine  
Methyl Ethyl ketone  
Methyl Mercaptan  
Isoamyl Alcohol  
Methyl Isobutyl ketone  
Isobutyl Alcohol  
Tertiary butyl alcohol

Nephtha ( Petroleum )  
N-Propyl Acetate  
Octanes  
Pentanes  
1-Pentanol ( amyl alcohol )  
Propane  
1-Propanol ( propyl alcohol )  
2-Propanol ( isopropyl alcohol )  
Propylene  
Styrene  
Toluene  
Turpentine  
Vinyl Acetate  
Vinyl Chloride  
Xylenes

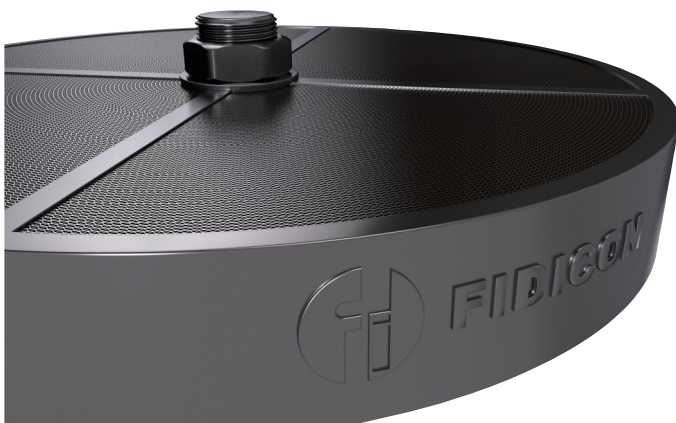

NEC	IEC	MESG	Test Gas List
Group II C	Group A	0.25	Acetylene
Group II C	Group B	0.28	Hydrogen
Group II B	Group B	0.65	NEC
Group II A	Group D	0.90	Propane
Group I	G.M	1.1	Methane

## Temperature Classification

Maximum Surface Temperature	NEC <sup>®</sup> 500 / CEC <sup>®</sup>	NEC <sup>®</sup> 505 - IEC GROUP II
450 °C - ( 842 °F )	T1	T1
300 °C - ( 572 °F )	T2	T2
280 °C - ( 536 °F )	T2A	
260 °C - ( 500 °F )	T2B	
230 °C - ( 446 °F )	T2C	
215 °C - ( 419 °F )	T2D	
200 °C - ( 392 °F )	T3	T3
180 °C - ( 356 °F )	T3A	
165 °C - ( 329 °F )	T3B	
160 °C - ( 320 °F )	T3C	T4
135 °C - ( 275 °F )	T4	
120 °C - ( 248 °F )	T4A	
100 °C - ( 212 °F )	T5	T5

## STANDARD FLAME ARRESTER SELECTION CRITERIA

Parameters	End of Line Type	In-Line Type	Detonation Type
Maximum Length of Pipe Between Arrester & Ignition Source with <b>No Bends</b> .	Mounted on End of Pipe	20 Ft. / 6m	No Limit
Maximum Length of Pipe Between Arrester & Ignition Source with <b>1 to 90 Degree Bend</b> .	Mounted on End of Pipe	20 Ft. / 6m	No Limit
Maximum Length of Pipe Between Arrester & Ignition Source with <b>Multiple Bends</b> .	Mounted on End of Pipe	20 Ft. / 6m	No Limit
Maximum Stabilization at stoichiometric mixture & ambient temperature exceed at 140°F/ 60°C	5 Minutes	5 Minutes 30 Minutes (factory approved units)	2 Hours
Operating Pressure	Atmospheric	106 kPa	143 kPa

### NEC Group "C" or IEC Group IIB3

Parameters	End of Line Type	In-Line Type	Detonation Type
Maximum Length of Pipe Between Arrester & Ignition Source with <b>No Bends</b> .	Mounted on End of Pipe	6 Ft. / 2m (Open Ended Pipe)	No Limit
Maximum Length of Pipe Between Arrester & Ignition Source with <b>1 to 90 Degree Bend</b> .	Mounted on End of Pipe	6 Ft. / 2m (Open Ended Pipe)	No Limit
Maximum Length of Pipe Between Arrester & Ignition Source with <b>Multiple Bends</b> .	Mounted on End of Pipe	Not recommended for Multiple Bends	No Limit
Maximum Stabilization at stoichiometric mixture & ambient temperature exceed at 140°F/ 60°C	5 Minutes	5 Minutes	15 Minutes
Operating Pressure	Atmospheric	106 kPa	143 kPa

### NEC Group "B" or IEC Group IIB3

Parameters	End of Line Type	In-Line Type	Detonation Type
Maximum Length of Pipe Between Arrester & Ignition Source with <b>No Bends</b> .	Mounted on End of Pipe	4 Ft. / 4.5m (Open Ended Pipe)	No Limit
Maximum Length of Pipe Between Arrester & Ignition Source with <b>1 to 90 Degree Bend</b> .	Mounted on End of Pipe	Not Recommended for Multiple Bends	No Limit
Maximum Length of Pipe Between Arrester & Ignition Source with <b>Multiple Bends</b> .	Mounted on End of Pipe	Not recommended for Multiple Bends	No Limit
Maximum Stabilization at stoichiometric mixture & ambient temperature exceed at 140°F/ 60°C	2 Minutes	2 Minutes	15 Minutes
Operating Pressure	Atmospheric	106 kPa	122 kPa

### IEC Group IIA Gases or NEC Group "D"

Parameters	End of Line Type	In-Line Type	Detonation Type
Maximum Length of Pipe Between Arrester & Ignition Source	Mounted on End of Pipe	2 In. to 6.5 Ft. 3 In. to 7 Ft. 4 In. to 10 Ft. 6 In. to 13.1 Ft. 8 In. to 13.3 Ft. 10 In. to 16.6 Ft. 12 In. to 19.7 Ft.	2 to 12 In.
Maximum Stabilization at stoichiometric mixture & ambient temperature <b>not to exceed at 60°C</b>	Mounted on End of Pipe	Not Recommended for Multiple Bends	No Limit
Maximum Stabilization at stoichiometric mixture & ambient temperature <b>exceed at 140°F/ 60°C</b>	Short time Burning Rating	Short time Burning Rating	Short time Burning Rating
Operating Pressure	Atmospheric	110 kPa	2 In. - 6 In. (143 kPa), 8 In.- 12 In. (116.5 kPa)

### IEC Group IIB3 Gases or NEC Group "C"

Parameters	End of Line Type	In-Line Type	Detonation Type
Maximum Length of Pipe Between Arrester & Ignition Source	Mounted on End of Pipe	2 In. to 8.3 Ft. 3 In. to 12.5 Ft. 4 In. to 16.6 Ft. 6 In. to 25 Ft. 8 In. to 33.3 Ft. 10 In. to 39.3 Ft. 12 In. to 39.4 Ft.	2 to 12 In.
Maximum Stabilization at stoichiometric mixture & ambient temperature <b>exceed at 140°F/ 60°C</b>	Short time Burning Rating	Short time Burning Rating	Short time Burning Rating
Operating Pressure	Atmospheric	110 kPa	118 kPa

# FLAME ARRESTER

IN LINE CONCENTRIC BI-DIRECTIONAL TYPE

In Line Bi-Directional Flame Arrester helps in improving safety in situations where your system is having risks of combustion in pipeline in Uncertain or Both Directions.



## FUNCTIONALITY

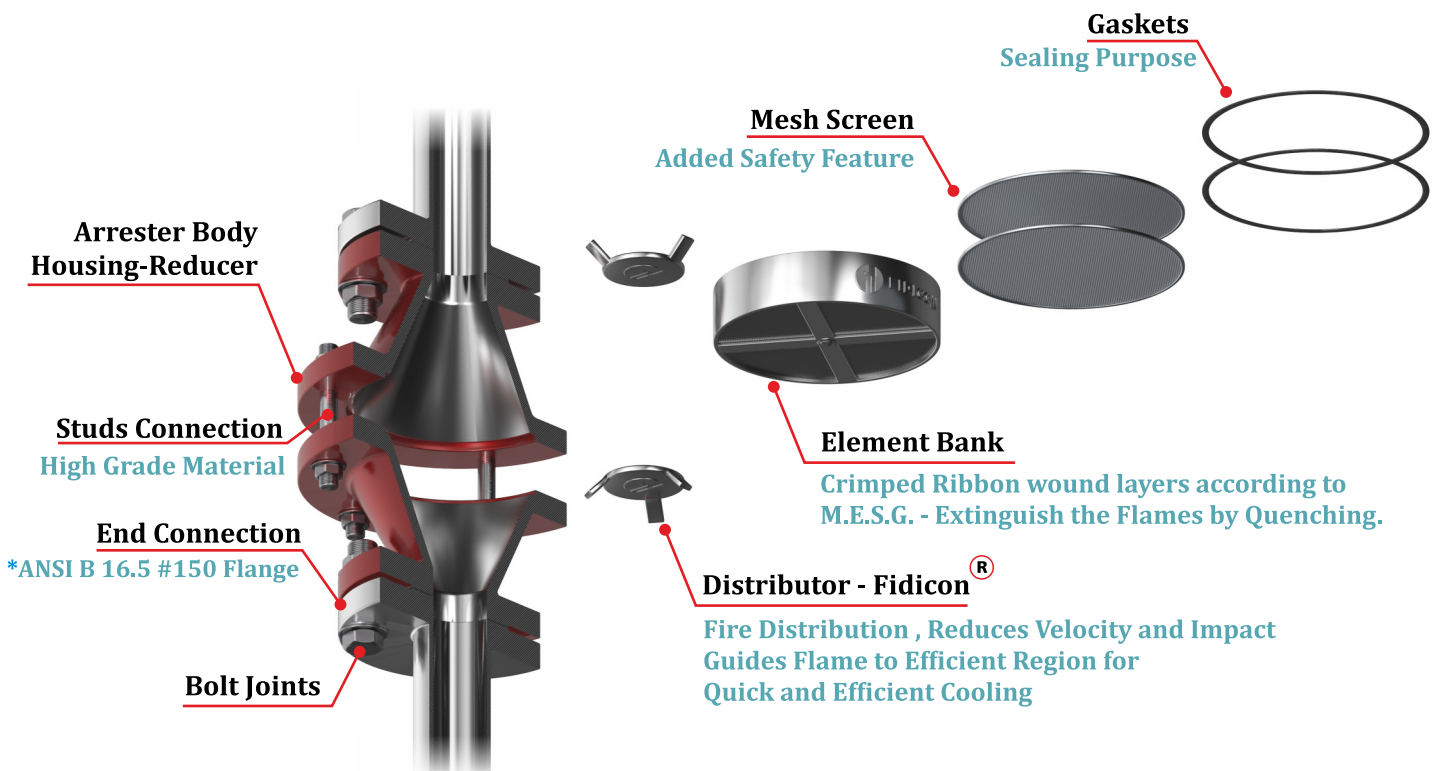

\* also Available other types as per Customer Request.

# FUNCTIONALITY

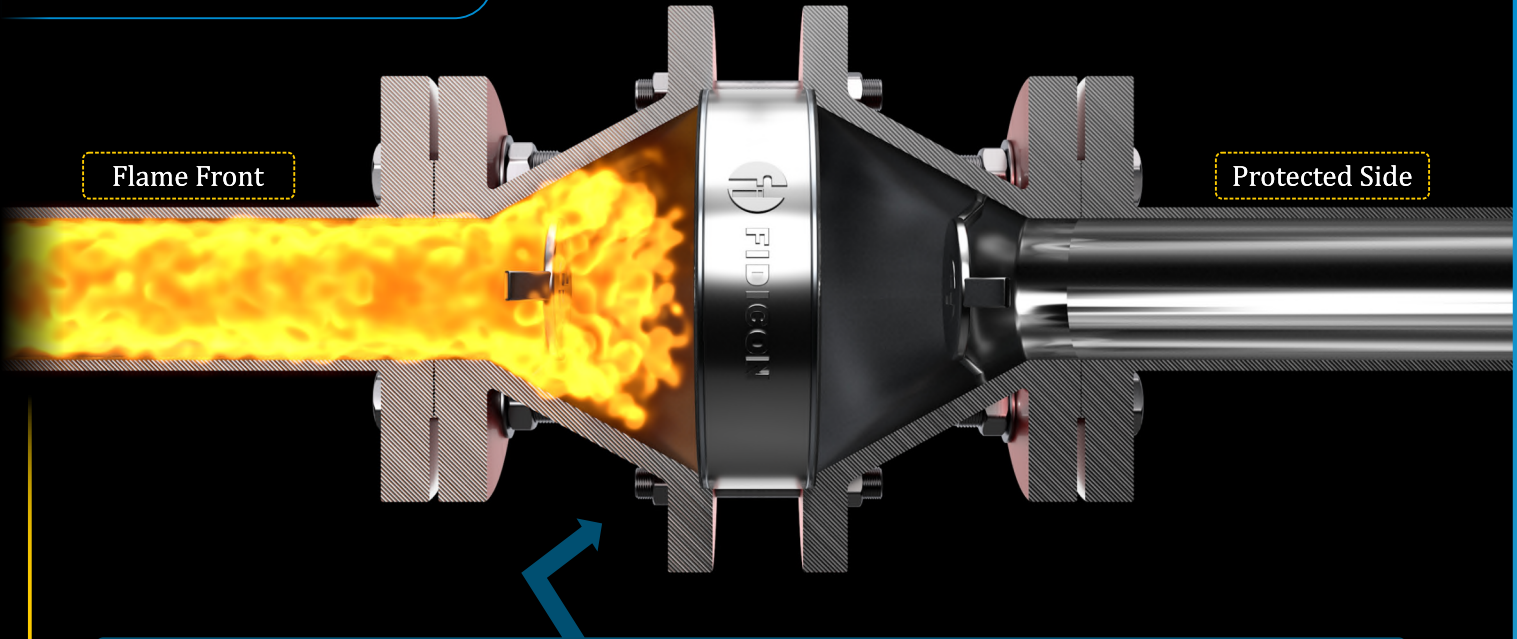

Flame Front

Protected Side

Flame Distribution into Small Voxels / Flamelets, Reducing the Explosion Flame Velocities upto 10x and resultant Impact on Element Bank, Further Guiding Flames to the Most Efficient Area where Flame can be quenched and Extinguished due to Heat Loss.

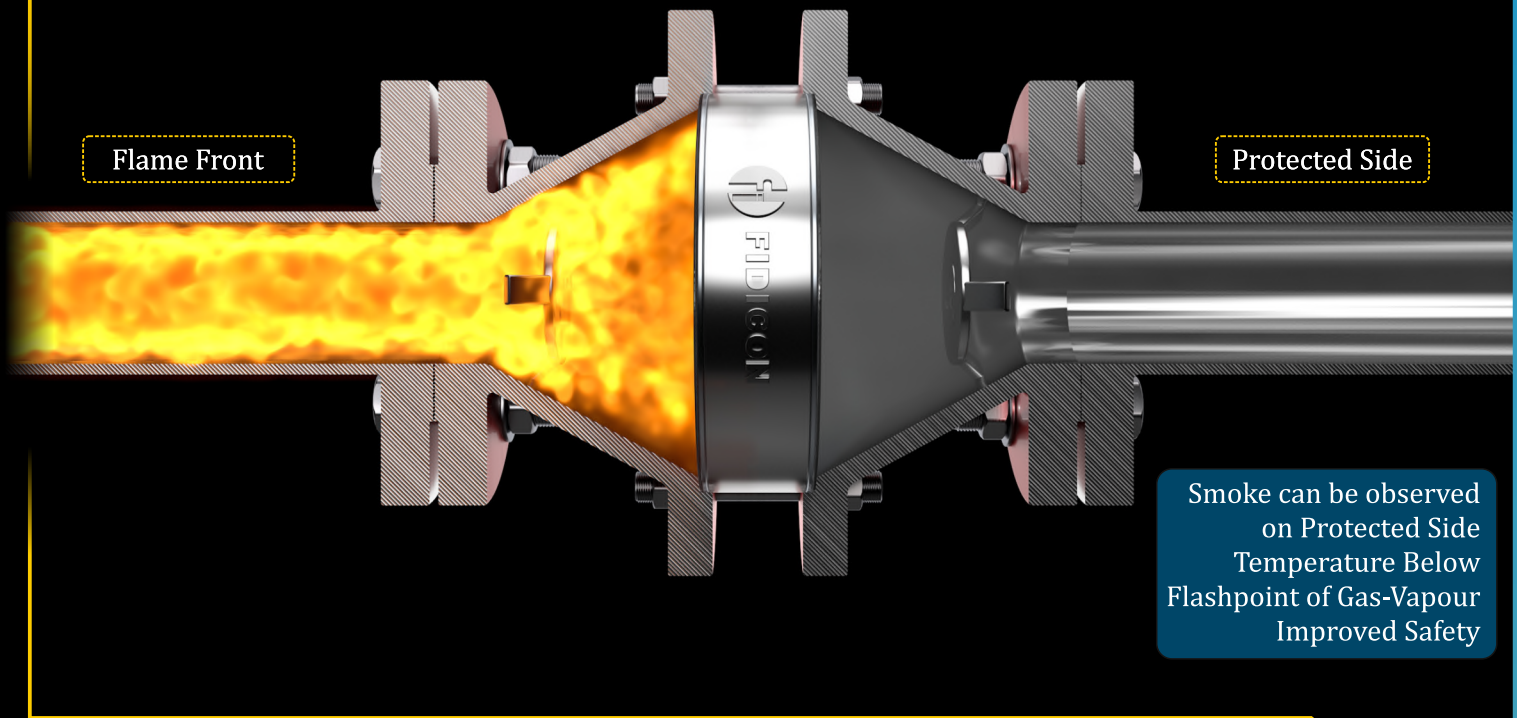

Flame Front

Protected Side

Smoke can be observed on Protected Side  
Temperature Below Flashpoint of Gas-Vapour  
Improved Safety

MESH SCREEN

ELEMENT - CRIMPED RIBBON LAYERS

Easy for Maintenance & Replacement  
Highly Durable Construction

FIDIGON

## APPLICATIONS

Flame arresters are used in different fields of chemical and engineering, as refining, pharmaceutical, chemical, petrochemical, pulp & paper, oil - exploration & production, landfills, mining, power generation and management, bulk liquid transportation, storage tanks etc.

Some cases flames involved with exothermic reaction rather than oxidation process which generates the combustible or reactive gases, process like blending, reacting, separation, mixing, drilling and digesting.

## BENEFITS OF PRODUCT

Safety will be improved implementing our flame arrester product, in your pipeline system which has potential ignition source and risks, it will prevent hazardous acts which can cause harm to personnel, extensive damages to equipments, process plants, environment and production loss.

## PERFORMANCE AFFECTING PARAMETERS

The Performance affecting part here is related with the MESG gap of flame element bank. gap holes may get clogged due to changes in operating conditions of service media - gas / vapor. so in order to maintain Efficiency it's advised to clean and treat Element Bank once in while to maintain it's steady performance and efficiency. it's kindly advised to follow the maintenance procedure from service and maintenance handbook provided or to consult our experts.

Flame arrester shall only be used in the conditions they have been designed and tested for. since the depth of the arrester is specified for certain conditions any changes in temperature, pressure or composition of gas / vapor entering arrester can cause flame spatial velocity to increase making the depth of the flame arrester insufficient to stop flame front - flow, the deflagration may continue downstream of the arrester.

## TESTING OVERVIEW

- Flow Capacity
- Dimensional Checks
- Endurance Burn & Continuous Flame Test
- Explosion & Flashback Test
- Hydrostatic Pressure Test
- Pneumatic Air Leakage test
- Leak Test
- Deflagration test
- Additional Burning Test
- Flame Transmission test etc.

\*and other tests may be performed as per customer request.





## STANDARDS FOLLOWED BY US.

- **API 2000** ( American Petroleum Institute )
- **API RP 2210** : Benefits & Detriments associated with use of Flame Arrester for Vents of Tanks Storing Petroleum Products.
- **API 2028** : Standard for Flame Arrester in Piping System.
- **USCG 33 CFR154** :  
(Appendix A : Guidelines for Detonation Flame Arrester)  
(Appendix B : Standard Specification for Tank vent Flame Arrester)
- **UL525** : Standard for Safety for Flame Arrester UL Gas & Oil Equipment Directory
- **CEN EN 12874** : Flame Arrester Performance Requirements, Test Methods & Limits for Use.
- **ASTM F 1273** : Standard Provides Minimum Requirements for Design, Construction, Performance, & Testing of Tank vent flame arrester.
- **IS 11006: 2011** : Flame Arrester Specifications
- **EN ISO 16852** : ATEX Compliance Atmospheric Explosible
- **ISO 16852:2016** : Flame Arrester Performance Requirements Test Methods, & Limits for use.
- **NEC/CEC** ( National Electrical Code / Canadian Electrical Code )
- **ASME B 31.3 : 2002**

## CERTIFICATIONS

- **IS 11006 : 2011 CSIR-CIMFR**
- **EN 12874 : EN ISO 16852 ATEX COMPLIANCE**
- **ISO 16852 : 2016**

## RECOMMENDED DISPOSAL

- Give it back to us & we will take care of recycling & possible disposal.
- User can dis-assemble the product in multiple stage
- The above may be handed over (state pollution board), authorized re-cycler item-wise.





## ENQUIRY SPECIFICATIONS :

1. Service
2. Density of Gas - Vapour
3. Flow Rates
4. Temperature Ranges
5. Pressure Ranges
6. Allowable Pressure Drop
7. Type of Product ( Inline, End of Line etc.)
8. Orientation
7. Connection Type / Pipe Size
8. Material Specifications ( For Body , Internal, Fasteners etc.)

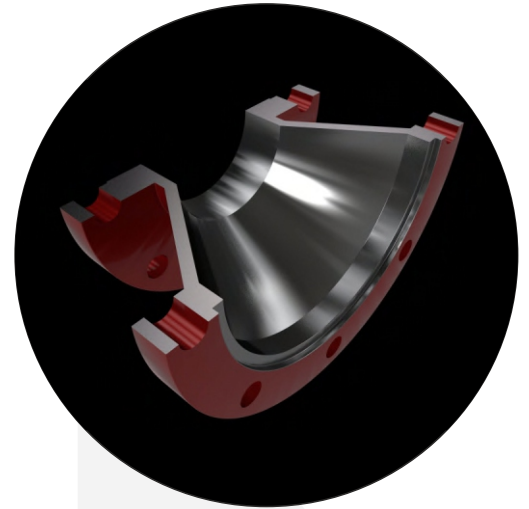

## STANDARD MATERIAL LIST :

Body M.O.C. (Reducer, Distributor )	Internal M.O.C. (Bank Shell, Element Bank)
ASTM A216 Gr. WCB ( CS ), SS 316, LM 6 ALUMINUM, SS 304, Forged Steel ASTM A 105, etc.	SS 316 ( ASTM A351 GR. CF8M), SS 304 ( ASTM A351 GR. CF8), HASTELLOY C (276), etc.
	other Materials can be used as per Customer Requirements
Fasteners	
SS 304 SS 202	

## RECOMMENDED SPARES :

- Flame Element Bank

## SOME SIMILAR RANGE OF PRODUCTS,

- End of Line Flame Arresters
- Eccentric Type Flame Arresters
- Detonation Type Flame Arresters
- Breather Valve
- Breather Valve cum Flame Arrester , and Many More.

### Any Query?

Contact us to Discuss,  
 Phone No: +91-2646-222238/223412  
 Mobile No: +91-9824418777  
[sales@fidicondevices.com](mailto:sales@fidicondevices.com)  
[info@fidicondevices.com](mailto:info@fidicondevices.com)  
 Address: Plot No. 1706/12, GIDC Ankleshwar,  
 Dist.: Bharuch, Gujarat, India 393002.



\*The given content on this manual could be change any time without prior notice. \*All the rights reserved by Fidicon only. Reproduction, transmission of this documents in any form or by any means without the written permission of Fidicon is prohibited. \*All legal disputes will be subjected to Ankleshwar Jurisdiction.  
 \*All Rights and Modifications Reserved in accordance with ISO 16016.